

# KD-4000 POUCH DISPENSER



## *SACHET-FRIENDLY CONSECUTIVE Feeding*

### Features

- Consecutive high-speed operation by **Rotary Cutter**
- Capacity: **280 sachets / minute**
- Sachet feeding & cutting synchronized with packing machine
- Sachet friendly smooth movement
- Easy operation by **5.7" color touch panel**
- Register up to **30 recipes**

## Basic Specs

Dispensing Capacity	280 sachets / minute
Sachet Size	Width: 50 – 100mm Length: 50 – 120mm Thickness: Max. 10mm
Sachet Type	3 seam-seal / 4 seam-seal
Cutting Accuracy	$\geq \pm 1.5\text{mm}$
Air Utility	0.5MPa 3 ℓ /min. (ANR) Dry air
Operation Atmosphere	0°C - 40°C (Humidity under 80%RH)
Weight	Approx. 210kg

## Overview

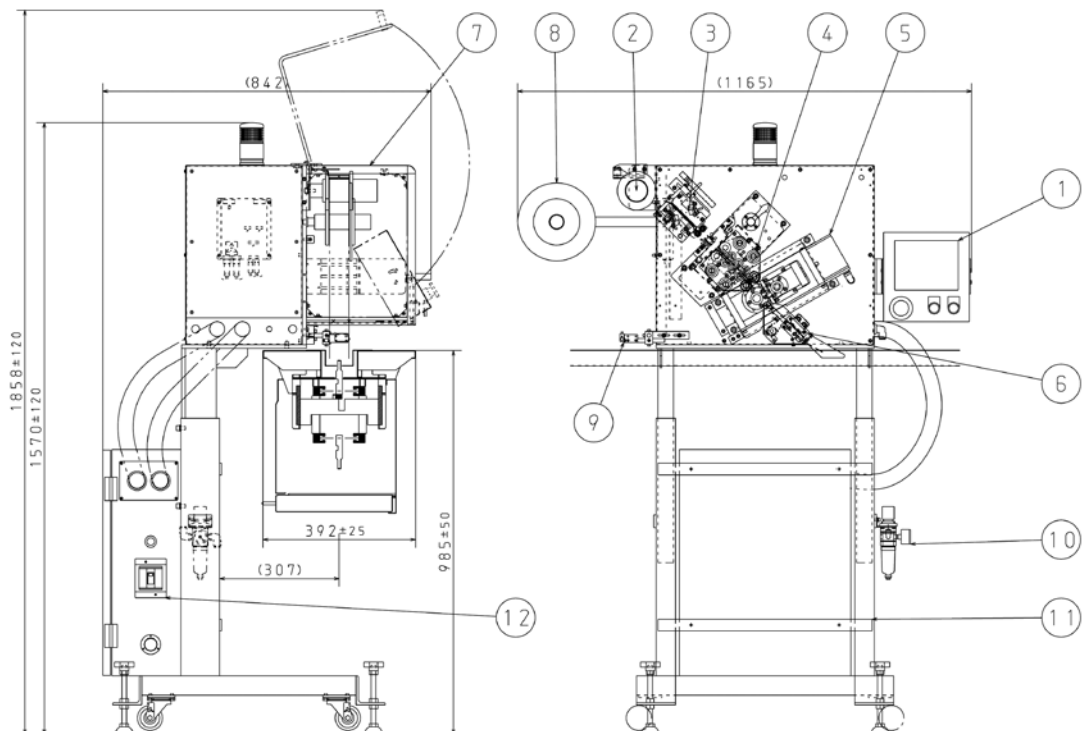

- |                        |                     |                         |
|------------------------|---------------------|-------------------------|
| ① Operation panel      | ⑤ Cutter unit       | ⑨ Noodle detection unit |
| ② Top roll unit        | ⑥ Belt chute unit   | ⑩ Air system            |
| ③ Pitch detection unit | ⑦ Safety cover unit | ⑪ Stand frame           |
| ④ Belt feed unit       | ⑧ Roll unit         | ⑫ Control box           |

### 株式会社 三橋製作所 MITSUHASHI CORPORATION

- |   |  |
|---|--|
| <input type="checkbox"/> Head Office/<br>Factory                  | 1 Sekizan-cho Yamanouchi Ukyo-ku Kyoto<br>615-0082 Japan                             |
| <input type="checkbox"/> Tokyo Office/<br>Overseas Sales Division | Yoshikuni Komagata Bldg. 9F 2-4-11 Komagata<br>Taitoh-ku Tokyo 111-0043 Japan        |
| <input type="checkbox"/> Kyushu Office                            | Minamikindai Building 6F, 4-2-10 Hakataekiminami<br>Hakata-ku Fukuoka 812-0016 Japan |

